



A6 RUNNING BOARDS

Assembly, Installation, Operation,
and Maintenance Instructions

PART NUMBER	AL6010B
INSTALL TIME	120 MINUTES

2009-2018 1500 DODGE RAM QUAD CAB (INCLUDES 2010-2024 1500 QUAD CAB "CLASSIC")

DEALER / INSTALLER	Provide a copy of these instructions to the end user of this product. These instructions provide important operating and safety information for proper usage of this product. Demonstrate the proper use of the product with the end user. Have the end user demonstrate that they understand the proper use of the product.
END USER	Read and follow all instructions included in this manual. Ask your Dealer/Installer for assistance if you do not understand the proper use of the product. Never remove any decals from the product. Failure to follow these instructions can result in injury or death.

PACKAGE CONTENTS

A6 RUNNING BOARDS (76in)	2	8mm X 20mm T-BOLTS	12
DRIVER/LEFT FRONT & CENTER MOUNTING BRACKETS	2	8mm-1.25 X 30 HEX BOLTS	18
PASSENGER/RIGHT FRONT & CENTER MOUNTING BRACKETS	2	8mm X 24mm X 2mm FLAT WASHERS	36
DRIVER/LEFT REAR MOUNTING BRACKET	1	8mm LOCK WASHERS	24
PASSENGER/RIGHT REAR MOUNTING BRACKET	1	8mm HEX NUTS	18
SUPPORT BRACKETS (DS FRONT/CENTER & PS REAR)	3	8mm NYLON LOCK NUTS	6
SUPPORT BRACKETS (PS FRONT/CENTER & DS REAR)	3	6mm X 25mm HEX BOLTS	12
8mm NUT/BOLT PLATES	6	6mm X 22mm X 2mm FLAT WASHERS	24
8mm PLASTIC RETAINERS	6	6mm NYLON LOCK NUTS	12

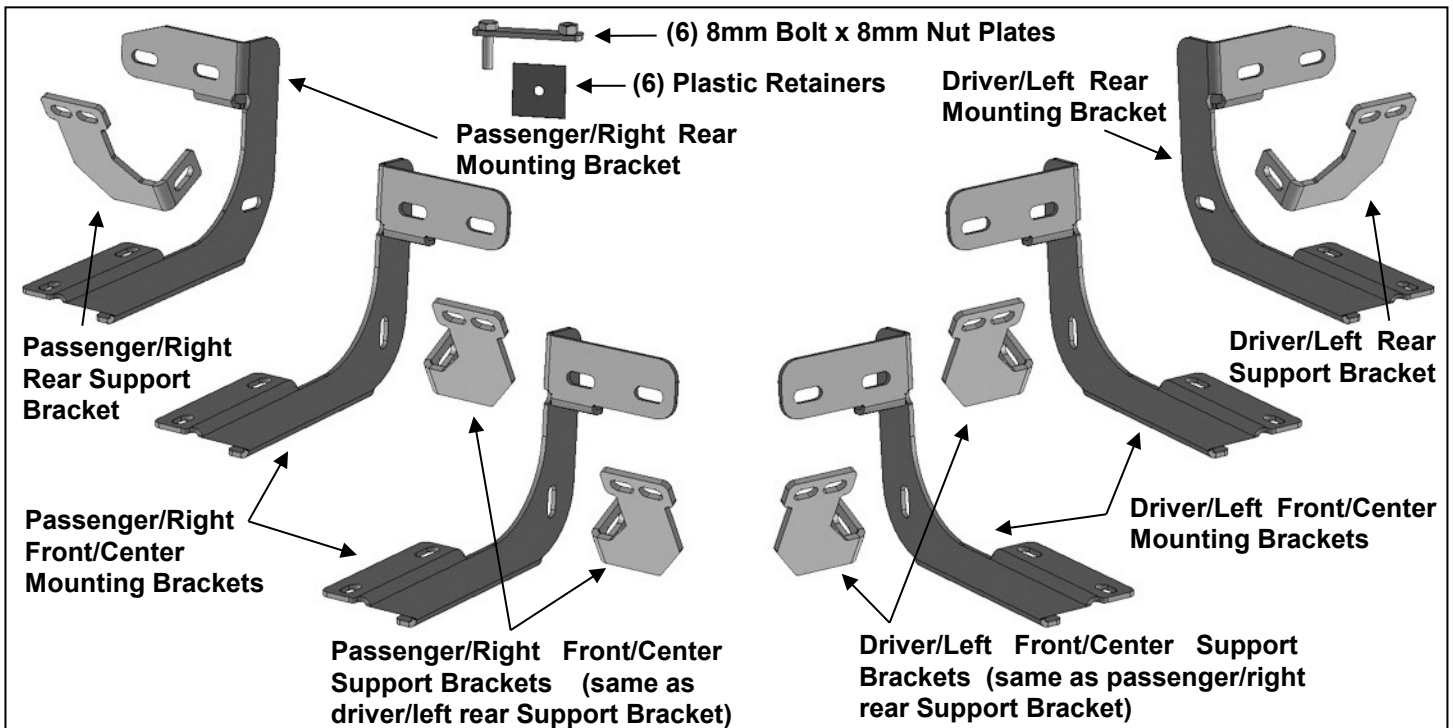

PROCEDURE

1. REMOVE CONTENTS FROM BOX. VERIFY ALL PARTS ARE PRESENT. READ INSTRUCTIONS CAREFULLY BEFORE STARTING INSTALLATION. DRILLING MAY BE REQUIRED.

2. Starting at the front of the driver/left side of the vehicle, remove the sealing tape covering the factory holes in the side of the inner panel, **(Figure 1)**.

3. Determine the correct procedure to attach (1) driver/left side front/center Bracket for your model/year: **Models without factory threaded inserts in body panel:**

a. Partially thread an 8mm Hex Bolt into the threaded end of an 8mm Bolt/Nut Plate, **(Figure 2)**. Thread the Hex Bolt in until it is flush with the welded nut, **(Figure 3)**. Use the loose Hex Bolt as a handle and insert the Bolt/Nut Plate into the oval hole, **(Figure 4)**. Feed the threaded bolt on the Bolt/Nut Plate through one of the hex shaped factory holes. Thread (1) 8mm Plastic Retainer onto the threaded end and down tight against the body panel, **(Figure 5)**. **NOTE:** The Plastic Retainer is designed to keep the Bolt/Nut Plate from falling into the body panel and to aid in Bracket installation.

Driver/Left Side Installation Pictured

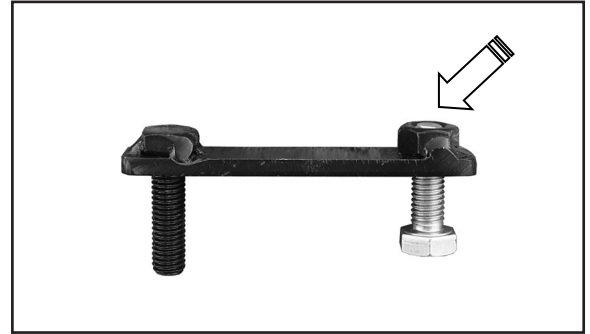

(Figure 3) Thread (1) 8mm Hex Bolt into the nut on the Bolt/Nut Plate. Stop when bolt reaches end of nut as pictured (arrow).

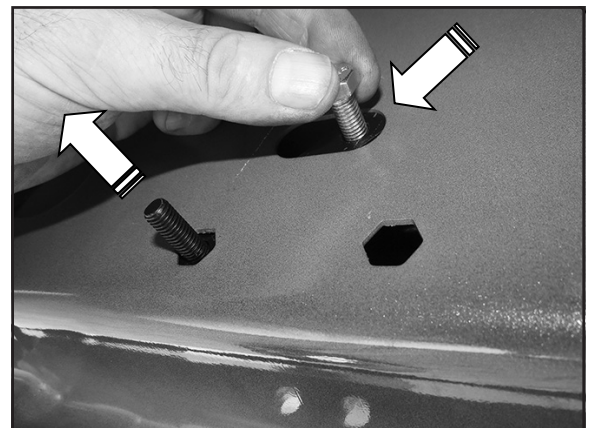

(Figure 4) Use the loose Hex Bolt as a handle. Insert the Bolt/Nut Plate into the oval hole and feed the threaded end out either factory hex shaped hole. **IMPORTANT:** Do not let go of the loose hex bolt until after Plastic Retainer has been threaded onto bolt (Figure 5).

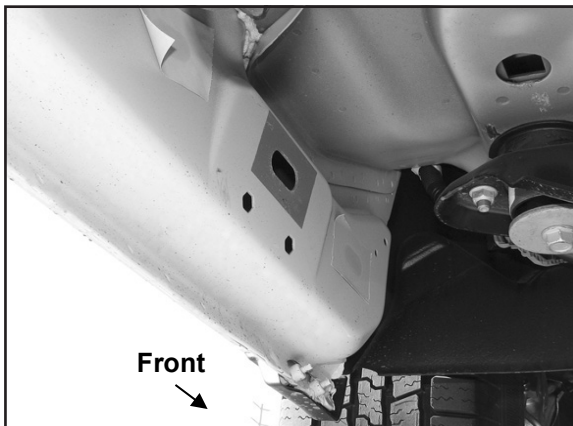

(Figure 1) 2009-mid 2015 driver/left front mounting location (Note no factory holes in pinch weld on 2009-2012 models).

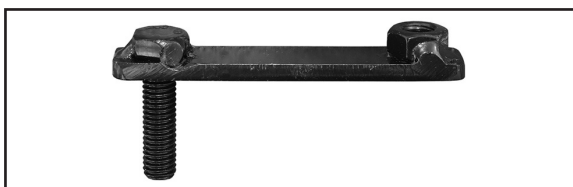

(Figure 2) 8mm Bolt/Nut Plate. **NOTE:** Bolt/Nut Plate is not required on models with threaded mounting holes (see Figure 9).

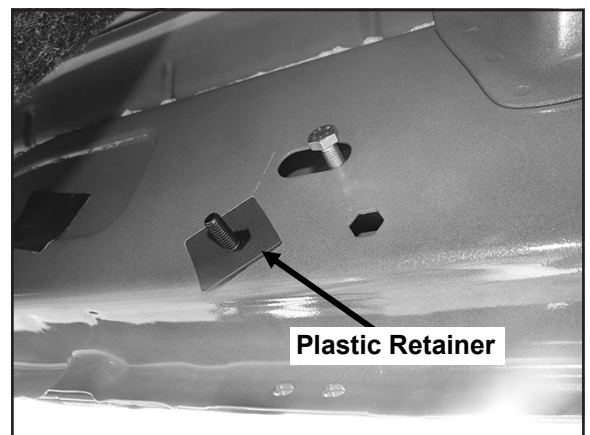

(Figure 5) Thread Plastic Retainer onto Bolt/Nut Plate to hold Bolt/Nut Plate in position.

PROCEDURE (CONTINUED)

3. **b.** Select (1) driver/left Front/Center Mounting Bracket, **(Figure 6)**. Slide the Bracket over the bolt on the Bolt/Nut Plate, **(Figure 7)**.

c. Remove the 8mm Hex Bolt from the nut on the Bolt/Nut Plate from **Step 3a**. Rotate the Bolt on the Bolt/Nut Plate until the threaded nut lines up with the remaining hole in the Mounting Bracket and body panel, **(Figure 7)**. Attach the Bracket to the threaded nut on the Bolt/Nut Plate with (1) 8mm x 30mm Hex Bolt, (1) 8mm Lock Washer and (1) 8mm Flat Washer, **(Figure 8)**.

Driver/Left Side Installation Pictured

Remove loose Hex Bolt and rotate Bolt/Nut Plate to line up nut with body panel and Mounting Bracket (see arrow)

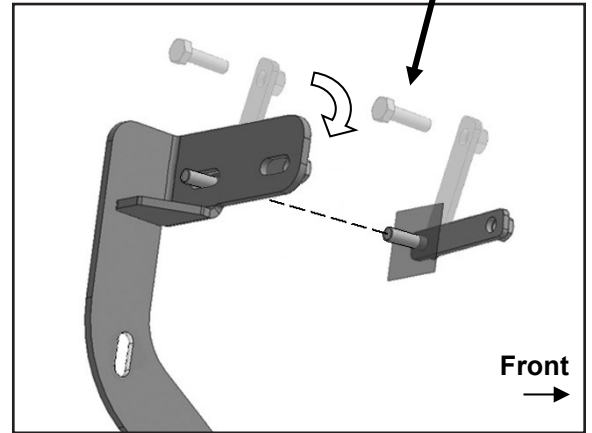

(Figure 7) Slide Bracket over bolt on Bolt/Nut Plate.

8mm Hex Bolt
8mm Lock Washer
8mm Flat Washer

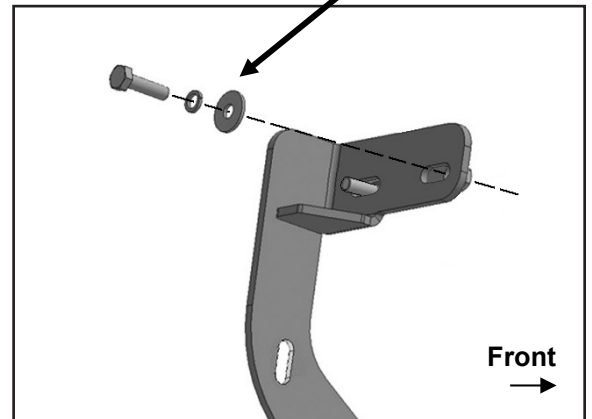

(Figure 8) Attach Bracket to nut on Bolt/Nut Plate.

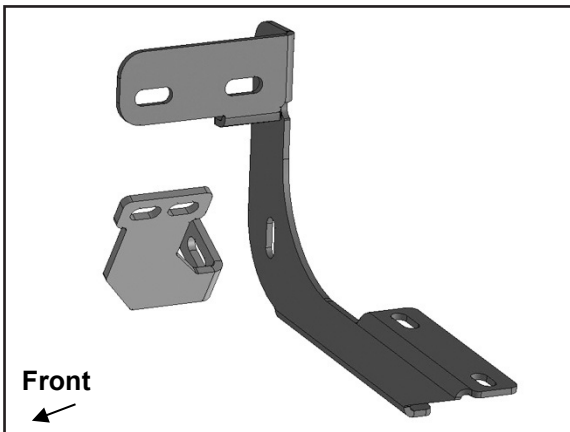

(Figure 6) Driver/left front/center Mounting Bracket and (1) driver/left front/center Support Bracket. **NOTE:** Driver/left front/center Support Brackets are the same as the passenger/right rear Support Bracket.

PROCEDURE (CONTINUED)

3. **d.** Attach the Bracket to the bolt on the Bolt/Nut Plate with (1) 8mm Flat Washer, (1) 8mm Lock Washer and (1) 8mm Hex Nut, (**Figures 9 & 12**). Do not tighten at this time.

e. Do not fully tighten hardware at this time.

Models with factory mounting holes in body panel:

Attach (1) driver/left Front/Center Bracket directly to the threaded mounting holes with (2) 8mm x 30mm Hex Bolts, (2) 8mm Lock Washers and (2) 8mm Flat Washer, (**Figures 10-12**). Leave hardware loose.

Driver/Left Side Installation Pictured

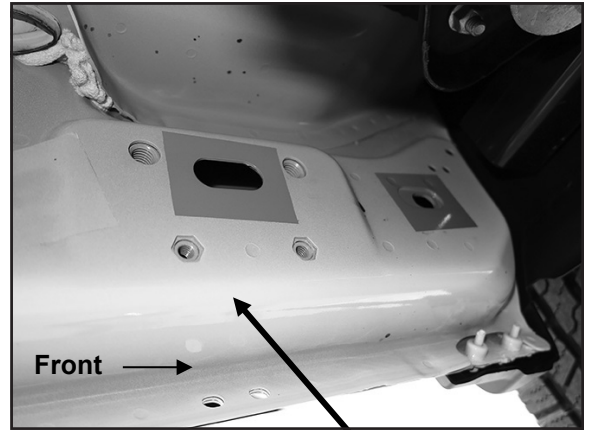

(Figure 10) Example of model with factory installed threaded mounting holes.

(2) 8mm Hex Bolts
(2) 8mm Lock Washers
(2) 8mm Flat Washers

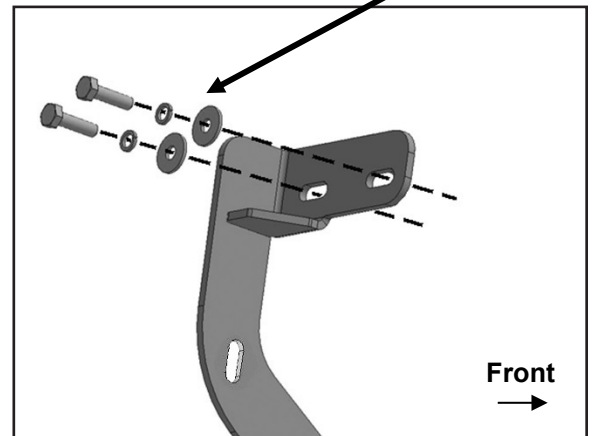

(Figure 11) Models with factory installed threaded holes in mounting locations. Attach driver/left front Mounting Bracket directly to threaded holes.

8mm Flat Washer
8mm Lock Washer
8mm Hex Nut

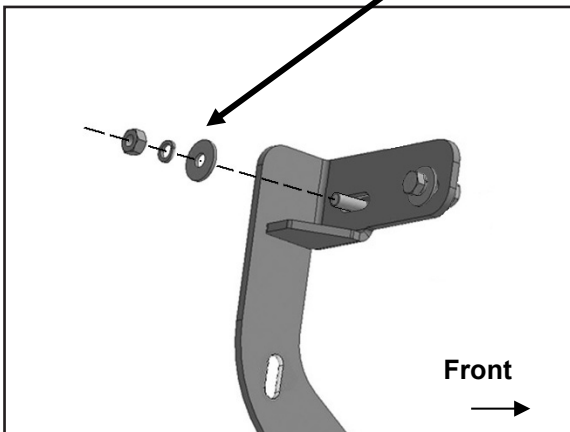

(Figure 9) Attach Bracket to bolt on Bolt/Nut Plate.

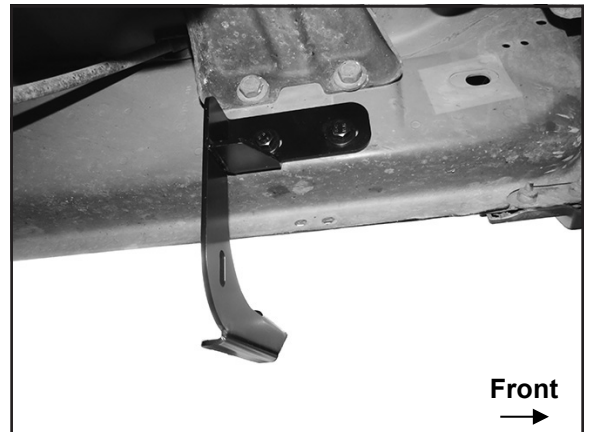

(Figure 12) Driver/left front Bracket installed.

PROCEDURE (CONTINUED)

4. Next, select (1) driver/left Front/Center Support Bracket. Attach the Bracket to the front facing side of the Front Bracket with (1) 8mm x 30mm Hex Bolt, (2) 8mm Flat Washers and (1) 8mm Nylon Lock Nut, **(Figure 13)**. Rotate the Support Bracket to the back of the pinch weld. Line up the slots in the top of the Support Bracket with the (2) factory holes in the pinch weld. Attach the Bracket to the back of the pinch weld with (2) 6mm x 25mm Hex Bolts, (4) 6mm Flat Washers and (2) 6mm Nylon Lock Nuts, **(Figure 14)**. Do not fully tighten hardware at this time. **IMPORTANT:** 2009-12 models may not be equipped with factory holes and will require drilling through the pinch weld to attach the Support Bracket. Do not drill through pinch weld at this time, **(see Step 12)**.

5. Move along the side of the body panel to the center mounting location, **(Figure 15)**. Select the remaining driver/left Front/Center Bracket, **(Figure 6)**. Repeat the appropriate **Step 3** to install the Bracket, **(Figures 7-14)**. **IMPORTANT:** The front/center Brackets are different from the rear Mounting Bracket, (see illustration above-note direction of mounting plate).

6. Select (1) driver/left center/rear Support Bracket, **(Figure 13)**. Repeat **Step 4** to attach the Support Bracket to the front of the center Bracket and holes in the pinch weld if equipped, **(Figure 14)**.

Driver/Left Side Installation Pictured

8mm Hex Bolt
(2) 8mm Flat Washers
8mm Nylon Lock Nut

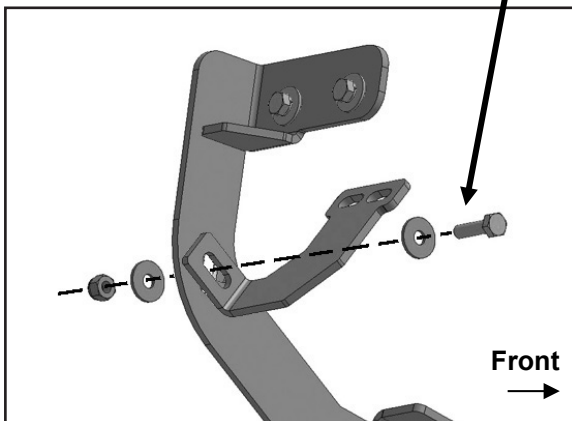

(Figure 13) Attach (1) Driver/left front Support Bracket to front facing side of Front Bracket.

(2) 6mm Hex Bolts
(4) 6mm Flat Washers
(2) 6mm Nylon Lock Nuts

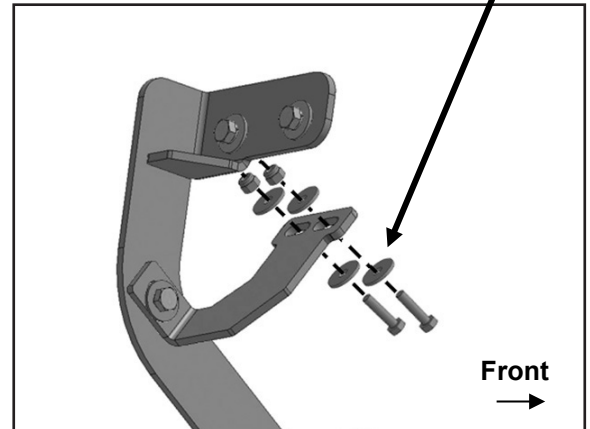

(Figure 14) Models with factory holes in pinch weld only. Attach Support Bracket to back of pinch weld.

IMPORTANT: 2009-2012 models without holes in pinch weld will require drilling 1/4" holes through pinch weld to attach driver side front support bracket. Do complete installation of running boards first, level running board before drilling holes for support brackets.

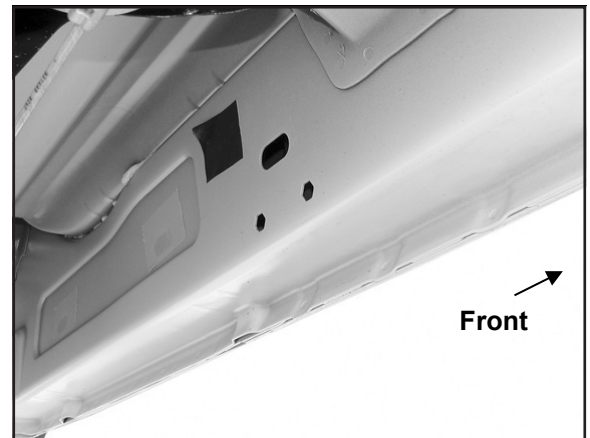

(Figure 15) Driver/left center mounting location.

PROCEDURE (CONTINUED)

7. Move to the rear location, **(Figure 16)**. Select the driver/left Rear Bracket, **(Figure 17)**. Repeat **Step 5** to attach the Bracket to the rear mounting location, **(Figure 18)**.

8. Select (1) driver/left rear Support Bracket, **(Figure 17)**. Repeat **Step 5** to attach the Support Bracket to the back of the Rear Bracket and holes in the pinch weld if equipped, **(Figures 19 & 20)**.

Driver/Left Side Installation Pictured

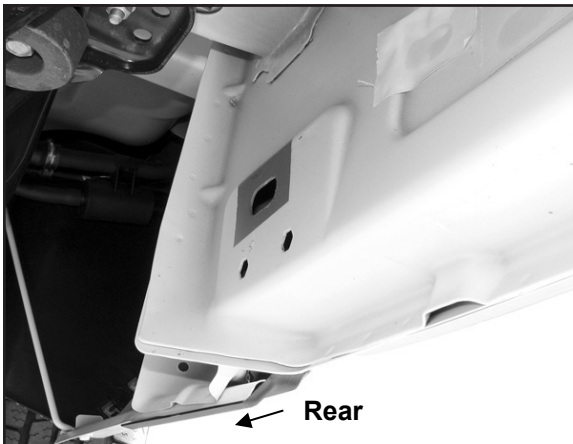

(Figure 16) Driver/left rear mounting location.

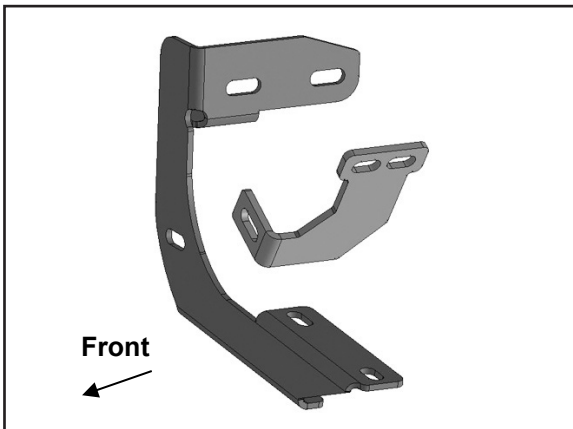

(Figure 17) Driver/left rear Mounting Bracket and Support Bracket.



(Figure 18) Driver/left rear Bracket installed.

(2) 6mm Hex Bolts
(4) 6mm Flat Washers
(2) 6mm Nylon Lock Nuts

8mm Hex Bolt
(2) 8mm Flat Washers
8mm Nylon Lock Nut

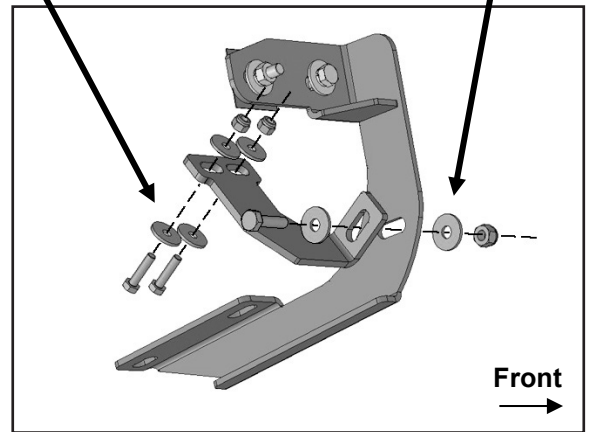

(Figure 19) Attach (1) driver/left rear Support Bracket to rear facing side of driver/left rear Mounting Bracket.

IMPORTANT: 2009-2012 models without holes in pinch weld will require drilling 1/4" holes through pinch weld to attach driver side front support bracket. Do complete installation of running boards first, level running board before drilling holes for support brackets.



(Figure 20) Driver/left Rear Bracket assembly complete installation.

PROCEDURE (CONTINUED)

9. Carefully unwrap the Running Boards. Select (1) Running Board. Insert (3) T-Bolts into each channel in the bottom of the Running Board, (**Figure 21**).

10. With assistance, place the Running Board on top of the Brackets. Guide the T-Bolts in the Running Board down through the slots in the Brackets, (**Figures 22 & 23**).

IMPORTANT: Do not slide, (front to back), the Running Board on the Brackets or damage to the finish may result.

11. Attach the Running Board to the Brackets with (6) 8mm Flat Washers, (6) 8mm Lock Washers and (6) 8mm Hex Nuts, (**Figures 22 & 23**). Do not tighten hardware.

Driver/Left Side Installation Pictured

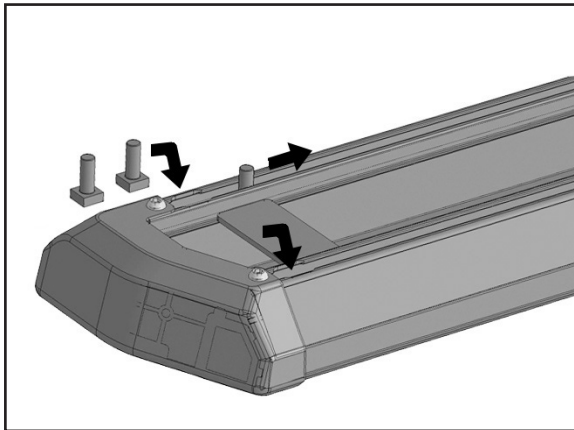

(Figure 21) Insert (3) 8mm T-Bolts into each channel in the bottom of the Running Board.

IMPORTANT: 2009-2012 models without holes in pinch weld will require drilling 1/4" holes through pinch weld to attach driver side front support bracket. Do complete installation of running boards first, level running board before drilling holes for support brackets.

(2) 8mm Flat Washers
(2) 8mm Lock Washers
(2) 8mm Hex Nuts

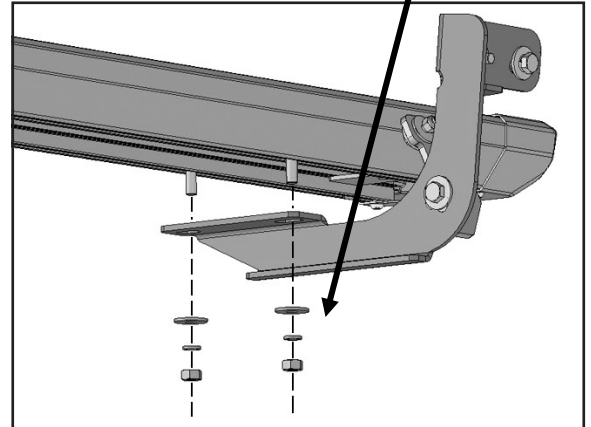

(Figure 22) Attach the Running Board to the driver/left front Mounting Bracket.

(2) 8mm Flat Washers
(2) 8mm Lock Washers
(2) 8mm Hex Nuts

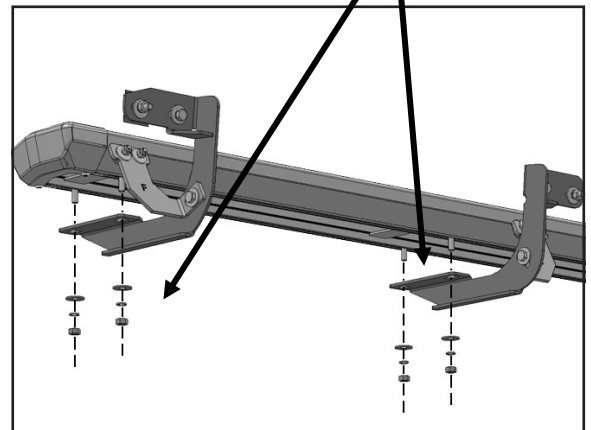

(Figure 23) Attach the driver/left Running Board to the center and rear Brackets.

PROCEDURE (CONTINUED)

12. Properly level and adjust the Running Board and fully tighten all hardware.

2009-12 models requiring drilling through pinch weld for driver/left side Support Brackets:

a. Make sure the Running Board is level to the vehicle. Adjust and tighten all mounting hardware.

b. Line up the slots on the Support Brackets with the back of the pinch weld. Mark the location of the slots onto the pinch weld.

c. Drill (2) 1/4" holes through the pinch weld for each Support Bracket. **IMPORTANT:** Do not drill too close to the bottom edge of the pinch weld. Adjust the Brackets as necessary to move the slots up the body panel away from the edge. Drill the holes toward the outside of the slots.

d. Attach each Support Bracket to the pinch weld with (2) 6mm Hex Bolts, (4) 6mm Flat Washers and (2) 6mm Nylon Lock Nuts, (**Figures 14 & 19**). Check the Running Board for level then fully tighten all hardware.

13. Move to the passenger/right side of the vehicle. Remove tape covering front, center and rear mounting locations. Repeat **Steps 2-12** for passenger/right side Running Board installation. **NOTE:** Measure the distance from the passenger/right front wheel opening or front mud flap to the front end of the passenger/right running board. Apply this measurement to the driver/left Running Board. **IMPORTANT:** Refer to the illustration on **Page 1** to identify the correct Mounting Bracket for each of the locations.

14. Do periodic inspections to the installation to make sure that all hardware is secure and tight.

To protect your investment, Do not use any type of polish or wax that may contain abrasives that could damage the finish. Mild soap may be used to clean the Running Board.

PRODUCT CARE

- Periodically check the product to ensure all fasteners are tight and components are intact.
- Regular waxing is recommended to protect the finish of the product.
- Use ONLY Non-Abrasive automotive wax. Use of any soap, polish or wax that contains an abrasive is detrimental and can scratch the finish leading to corrosion.
- Mild soap may be used to clean the product for Black finish.

FAQs

Hardware and mounting brackets are not aligning properly.	Ensure that hardware is being used on the correct side of vehicle. In some cases, the hardware may appear the same for driver and passenger side but may alter the alignment of mounting location. Check mounting brackets for both sides.
Products are thumping / rattling after Installation.	Ensure that all required mounting brackets/hardware's are installed & tightened correctly. Suggest using white Lithium/regular grease between metal-to-metal contact.
Missing / Excess Hardware.	Recheck hardware count as per the part list.
Product not installing properly.	Ensure the Year/Make/Model as well as cab and bed dimensions are correct for the application. Review all steps for installation to ensure they were followed correctly.
Who should be contacted for questions regarding product / installation assistance?	www.trailfx.com / support@trailfx.com or 1-(866) 638-4870

CONTACT US

WEBSITE: TrailFX.com

PHONE: 1-866-638-4870

EMAIL: support@trailfx.com

WARRANTY TERMS

Black Powder Coated: Limited Lifetime Warranty

TrailFX and Keystone Automotive Operations Inc. make no guarantees or warranties for products not manufactured by Keystone Automotive Operations Inc. Such products are covered solely under any applicable warranty of the manufacturer. It is always recommended that the operating instructions and warranty instructions provided by the manufacturer are followed.

Keystone Automotive Operations Inc. warrants its products to be free from manufacturing and material defects to the original purchaser for the length of warranty stated above from the date of retail purchase. If any products are found to have a manufacturing or material defect, the product will be replaced or repaired at the option of TrailFX and Keystone Automotive Operations Inc. with proof of purchase by the original purchaser. The original purchaser shall pay all transportation and shipping costs associated with the return of the defective product and the defective product shall become the property of Keystone Automotive Operations Inc.

This Warranty applies to Keystone Automotive Operations Inc. products used for individual and recreational purposes. Commercial usage of the Keystone Automotive Operations Inc. products limits the warranty to 90 days from the date of purchase.

This Warranty applies only to Keystone Automotive Operations Inc. products which are found to be defective in manufacturing or material. This warranty does not apply to normal wear and tear of the finish placed on Keystone Automotive Operations Inc. products.

TrailFX and Keystone Automotive Operations Inc. are not responsible for any labor costs incurred for removal or replacement of the defective product.

TrailFX and Keystone Automotive Operations Inc. are not responsible for repair or replacement of any product under the limited warranty where the product was improperly installed, misapplied, altered, abused, neglected, overloaded, misused, or damaged as a result of an accident, including any use of the product not in accordance with all products operating and safety instructions.

Without limiting the generality of the foregoing, TrailFX and Keystone Automotive Operations Inc. shall under no circumstances be liable for any incidental or consequential loss or damage whatsoever arising out of, or in any way relating to any such breach of warranty or claimed defect in, or non-performance of the products. Some states do not allow the exclusion or limitation of incidental or consequential damages, so the above exclusion or limitation may not apply to you.

This limited warranty gives you specific legal rights, and you may also have other rights that vary from state to state.